

# Airliner™ Wireless Slate

## Specifications – Model WS100

### Physical Specifications

<b>Size</b>	Overall	11" W × 10 1/8" H × 1" D (27.9 cm × 25.7 cm × 2.5 cm)
	Active Screen Area	7 3/4" W × 6" H (19.7 cm × 15.2 cm) 9 3/4" (24.8 cm) diagonal
<b>Weight</b>	Airliner Wireless Slate	2 lb. (0.9 kg)
<b>Shipping Size</b>	Carton	11 1/2" W × 13 1/4" H × 3 3/4" D (29.2 cm × 33.7 cm × 9.5 cm)
<b>Shipping Weight</b>	Carton and Contents	4 lb. (1.8 kg)

All dimensions +/- 1/8" (3.2 mm). All weights +/- 1/2 lb. (0.2 kg).

### Standard Features

<b>Software</b>	SMART Board software and Notebook™ software. Free software upgrades are available at <a href="http://www.smarttech.com/support/software/index.asp">www.smarttech.com/support/software/index.asp</a> . Although the latest version of SMART Board software works with Windows® 98, the Airliner Wireless Slate requires Windows 2000 or Windows XP.
<b>Communication Interface</b>	Bluetooth™ wireless technology using HID protocol
<b>Electromagnetic Technology</b>	Allows you to rest your hand and write naturally on the transparent overlay, without interfering with the electronic ink
<b>Maximum Report Rate</b>	100 points per second
<b>Coordinate Resolution</b>	2032 lpi (80 lpmm)
<b>Bluetooth Adapter</b>	Class 2 adaptor allows wireless connectivity with an expected range of 52' (16 m) and a maximum range in free space of 164' (50 m)
<b>Underlay and Icon Strip</b>	Allows you to switch between the eraser, electronic ink colors (black, blue, red and green), right-mouse click, floating keyboard, screen capture and Control Panel
<b>Anti-Slip Feet</b>	Four anti-slip rubber feet keep the Airliner Wireless Slate stable when working on flat surfaces
<b>Buttons</b>	Two programmable buttons default to launching Floating Tools and Notebook software
<b>Pen</b>	Battery-free tethered pen +/- 0.5 mm accuracy with an average reading height of 5 mm
<b>Mouse</b>	Battery-free wireless fingerwheel mouse has continuous rotation, 24 notches per revolution
<b>Power Requirements</b>	6V DC, 450 mA from Class 2 power adapter
<b>Power Adapter</b>	Input Voltage: 100V–240V AC, 50 Hz–60 Hz, 0.3 VA Output Voltage: 6V DC, 1.0A
<b>Battery</b>	Rechargeable Lithium Polymer battery with 25–30 hours of life per charge, 3.7V, 1800 mAh
<b>Certifications</b>	CE, FCC
<b>Warranty</b>	Product warranty is governed by the terms and conditions of SMART's <i>Limited Equipment Warranty</i> that shipped with the SMART product at the time of purchase. Save all packaging materials for the duration of the limited warranty period. If you don't, and you must return merchandise for repair, you may be charged for the replacement packaging materials.

### Computer Requirements

<b>Windows® System Requirements</b>	Pentium® 233 MHz processor (450 MHz or faster recommended) 128 MB of RAM (256 MB recommended) Approximately 160 MB of free hard disk space for a full installation Windows 2000 or Windows XP Microsoft Internet Explorer 6.0 or later Macromedia Flash player version 7.0.19 or later (recommended) Available powered USB or serial port
<b>SMART Video Player Requirements</b>	Pentium 450 MHz processor (700 MHz or faster recommended) Windows 2000 or Windows XP. Does not run on the Windows NT operating system. Microsoft DirectX 8.1 End-User Runtime or later
<b>Macintosh Computers</b>	400 MHz processor (800 MHz or faster recommended) 128 MB of RAM (256 MB recommended) Mac OS X version 10.3.3 or later (with Java version 1.3.1 update 1 or later) 50 MB of free hard disk space for minimum installation, 115 MB for complete installation with Gallery collections Available powered USB port

**NOTE:** SMART Board software is not compatible with versions 10.3.0, 10.3.1 or 10.3.2 of the Mac OS X operating system. To use the handwriting recognition feature, you must have Mac OS X version 10.3.3 or later.

## Specifications – Model WS100

---

### Storage and Operating Specifications

**Storage** 14°F to 140°F (-10°C to 60°C) with 20–90% humidity, non-condensing

**Operating** 41°F to 104°F (5°C to 40°C) with 20–80% humidity, non-condensing

---

### SMART Order Numbers

**WS100** Airliner Wireless Slate

---

**SMART Technologies Inc.**  
1207 – 11 Avenue SW, Suite 300  
Calgary, AB T3C 0M5  
CANADA  
Phone +1.403.245.0333  
Toll Free 1.888.42.SMART (Canada/U.S.)  
info@smarttech.com www.smarttech.com

**SMART**  
Technologies™

© 2005 SMART Technologies Inc. All rights reserved. Airliner, SMART Board, Notebook and the SMART logo are trademarks of SMART Technologies Inc. Windows and Windows NT are registered trademarks of Microsoft Corporation in the U.S. and other countries. The Bluetooth word mark is owned by the Bluetooth SIG, Inc. and any use of such marks by SMART Technologies Inc. is under license. All other third-party product and company names may be trademarks of their respective owners. U.S. Patent Nos. 4,878,553; 4,999,461; 5,028,745; 5,448,263; 5,466,896; 5,600,105; 5,644,108; 5,679,930; 6,141,000; 6,326,954; 6,337,681; 6,741,267 and 6,747,636. Canadian Patent No. 2,058,219. Other U.S., Canadian and foreign patents pending. Specifications are subject to change without notice. 06/2005.

# Airliner™ Wireless Slate

## Specifications – Model WS100

Pen Holder  
(pen not shown)

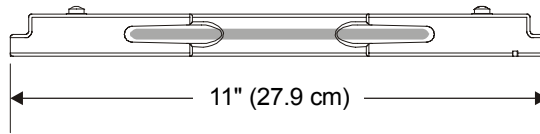

11" (27.9 cm)

Top View

1" (2.5 cm)

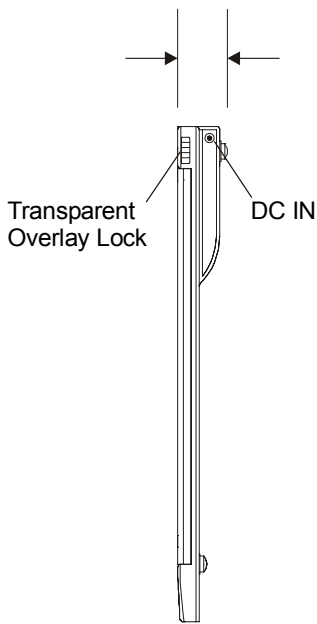

Side View

Power On/Off

Programmable Buttons

Power Indicator

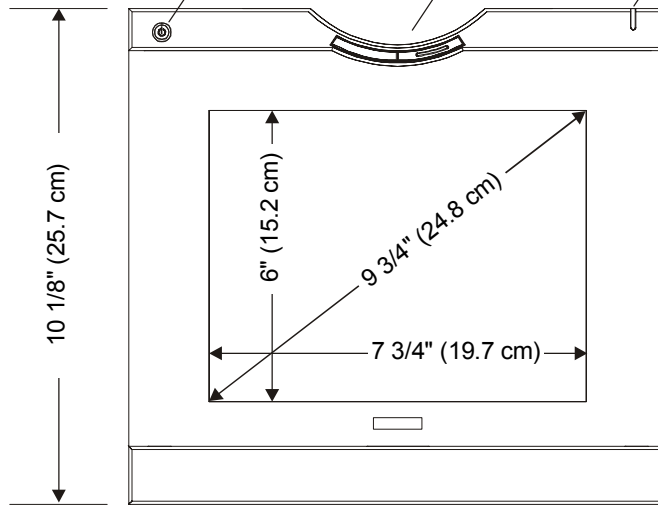

10 1/8" (25.7 cm)

6" (15.2 cm)

9 3/4" (24.8 cm)

7 3/4" (19.7 cm)

Front View

Anti-Slip Foot (x4)

Connect Button

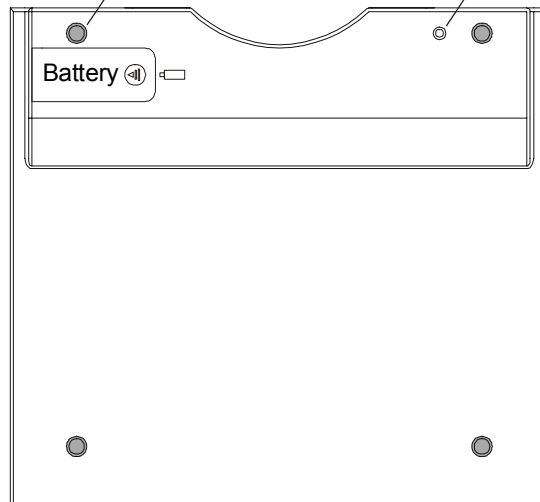

Battery

Back View

All dimensions +/- 1/8" (0.3 cm)

