

# TS Lightning™

## Interactive Whiteboard

Interact  
Explore  
Enlighten



Interruption-free meetings and classes



Interactive Projection on a Touch-sensitive Surface



Improve Group Interactivity

### Calibration-free

Introducing PolyVision's TS Lightning™ Series of Interactive Whiteboards - the world's first calibration-free interactive whiteboard. TS Lightning eliminates the need to perform the four, eight, or sixteen point calibration of standard interactive whiteboards so you can enjoy interruption-free meetings and classes!

If your projected image is ever out of alignment, simply press the projection icon on the TS series icon strip and calibration occurs instantly using Photonic Array Technology.

### Keep Your Audience Focused

TS Lightning boards include all the benefits of the regular TS Series, helping to dramatically improve group interactivity by allowing participants to listen and engage.

The TS Series digitally captures any notes written or projected onto the board, so your audience can focus on the session content rather than concentrating on taking notes. Notes can be provided in your choice of format: via e-mail, Internet, intranet, or printed copies.

### Maintain Message Consistency

There is little room for miscommunication when all session participants have the same notes; simply save your work to a computer for later distribution. Plus it's easy to review notes and annotations made during previous sessions and update presentations accordingly, eliminating the time crunch of preparing digital presentations.

TS Lightning:  
Present a calibration-free experience.

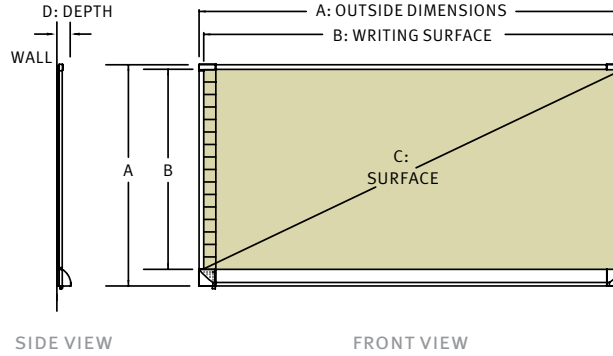

Interactive Whiteboard	Model TSL 400	Model TSL 600	Model TSL 800
Dimension A (HxW)	39.7 in. x 47.0 in. (1010mm x 1190mm)	47.7 in. x 67.0 in. (1210mm x 1700mm)	47.7 in. x 97.0 in. (1210mm x 2460mm)
Dimension B (HxW)	35.0 in. x 45.0 in. (889mm x 1140mm)	43.0 in. x 65.0 in. (1090mm x 1650mm)	43.0 in. x 95.0 in. (1090mm x 2410mm)
Dimension C (Diagonal)	56.9 in. (1446mm)	77.8 in. (1976mm)	104.3 in. (2649mm)
Dimension D (Depth)	3.0 in. (76.2mm)	3.0 in. (76.2mm)	3.0 in. (76.2mm)
Resolution	8000 x 8000	8000 x 8000	8000 x 8000
Weight	30 lbs. (13.62 kg)	55 lbs. (24.97 kg)	70 lbs. (31.78 kg)

#### Surface material

Touch-sensitive, low-glare, stain-resistant Teflon® surface

#### Connection

- USB connection to computer
- No external power required

#### Certification

CE, FCC Class A

#### Warranty

Two-year limited warranty, free upgrade to five years upon product registration

#### Accessories (Included)

- User Manual
- 3.25 inch (830mm) round eraser
- 15 foot (3m) USB cable

#### Features

- Use projector without calibration
- Easy to use icon strip
- Free Webster™ software included
- Transfer images via drag & drop, clipboard, or file export
- Anti-aliased markup including highlighters
- Real-time playback
- Multiple monitor support
- Save images in JPG, BMP, TIFF, WMF, HTM, PDF, PCT, MacPaint, PSD, PNG, Quicktime Image, and TGA

#### Recommended Computer Requirements

Microsoft Windows®:

32 megabytes RAM, Pentium 250 MHZ processor or better  
Windows 98, b2000, ME, XP, or tablet XP  
One USB port

Apple Macintosh®: (available January 2006)

32 megabytes RAM; a Power PC, G3, G4 or G5 processor  
Mac OS version 8, 9, or X  
One USB port

#### Options

- Mobile stand - supports models TSL 400 and TSL 600
- RM Easiteach® Studio educational software

Authorized PolyVision Dealer

PolyVision Corporation  
1.800.620.POLY  
info@polyvision.com  
www.polyvision.com

**POLYVISION**  
A Steelcase Company